

# Original Instructions

# **MAG-8100 SERIES**



**PROFESSIONAL LAWN MOWER BLADE SHARPENERS**



# THANK YOU,

We sincerely appreciate your decision to make Magna-Matic your lawn mower blade sharpener. We understand there are other choices in the marketplace, and we are extremely confident that after the first few blades you sharpen, it will be evident you've chosen the best machine for the job. Rest assured that if you have a question or problem you will have complete customer support for all of our products.

800-328-1110 (USA & CANADA) or 920-564-2366  
<https://www.magna-matic.com>

**Please be sure all the items are in the box and inspect for shipping damage, or for missing parts. Contact Magna-Matic right away to remedy any problems due to shipping. 800-328-1110**

## BOX INVENTORY

### *MAG-8100 (1/3 HP or 1/2 HP)*

- **MAG-8200 Sharpener**
- **(1) Grit Guard top**
- **(2) Grit Guard Sides**
- **(1) Grit Guard Bottom (can add port)**
- **(1) Crank handle**
- **(1) Spanner Wrench**
- **(1) Arbor Wrench**

### QUICK START VIDEOS

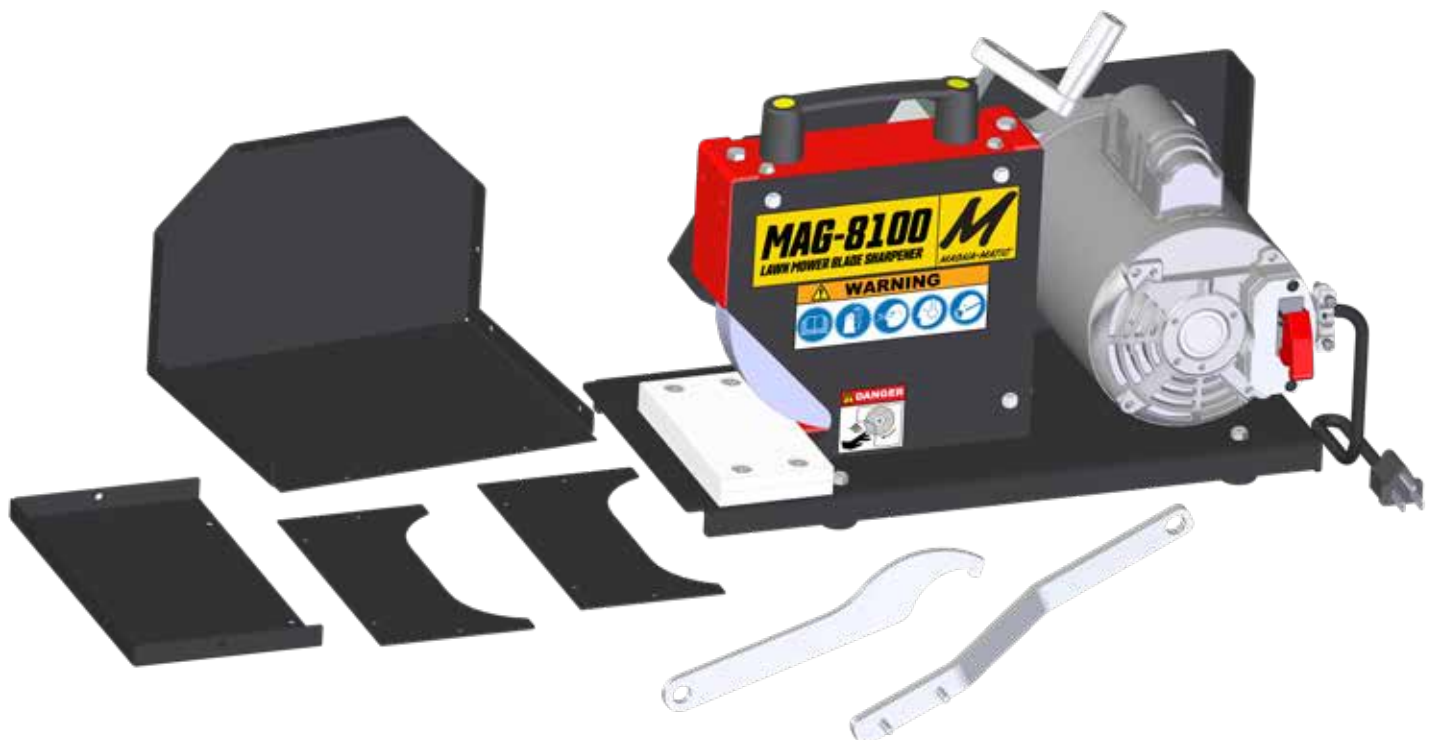

*This image shows 1/3 hp motor and non-ported grit guard bottom.*

# MAG-8100 SPECIFICATIONS

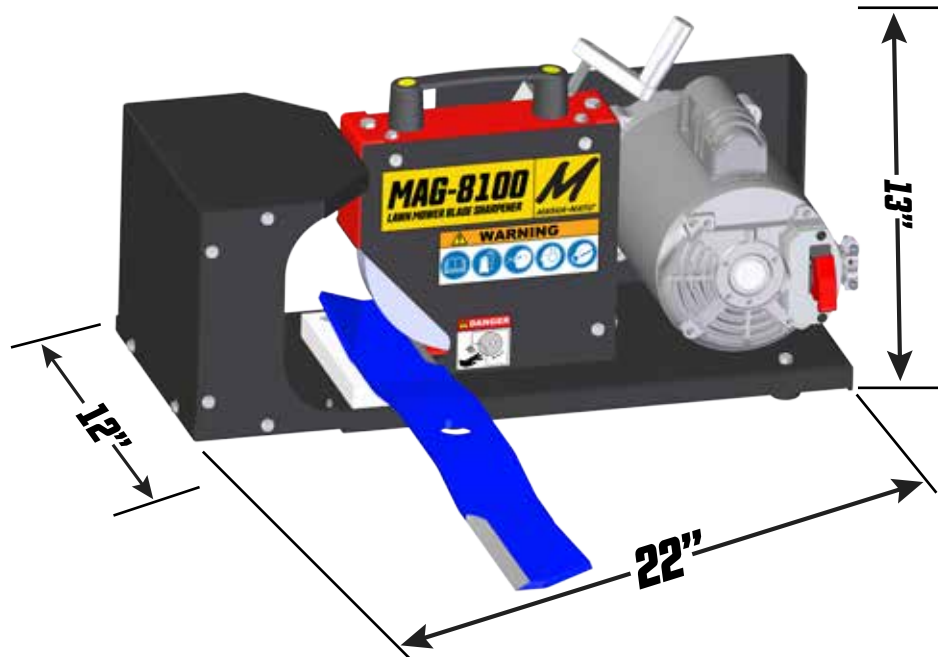

	MAG-8100 (North America)	MAG-8100 (Euro)	CE
LxWxH	22" x 12" x 13"	55 x 30 x 33 cm	
Weight	60 lbs	27 kg	
Ship Weight	65 lbs	29 kg	
Motor Specs	US MOTORS®	US MOTORS®	
Horse Power	1/3 or 1/2	1/3 or 1/2	
Motor RPM	3450	2850	
Hertz	60	50	
Volts	115	220	
Phase	1	1	
Amps (run)	10	6.5	
Capacitors	Single	Single	
Motor Type	1/3 HP ODP - 1/2HP TEFC	1/3 HP ODP - 1/2HP TEFC	
Direction	Single Direction	Single Direction	
Fan Cooled	Yes	Yes	
Transmission	Poly-V belt/pulley	Poly-V belt/pulley	
Grinding Wheels	NORTON® Abrasives	NORTON® Abrasives	
Wheel Dimensions	7" dia x 1" thick x 1-1/4" dia arbor	17.7 cm dia x 2.5 cm thick x 3.18 cm dia arbor	

# THE SAFE WAY IS THE ONLY WAY TO GRIND!



## WARNING

WHEN USING ELECTRIC TOOLS, BASIC SAFETY PRECAUTIONS SHOULD ALWAYS BE FOLLOWED TO REDUCE THE RISK OF FIRE, ELECTRIC SHOCK, AND PERSONAL INJURY.



## CAUTION



LAWN MOWER BLADES HAVE SHARP EDGES - ALWAYS WEAR PROTECTIVE GLOVES AND SAFETY GLASSES!











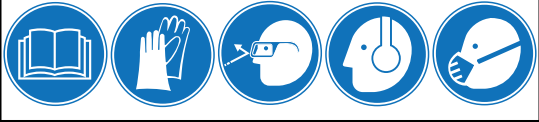

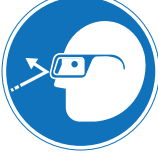
### Before handling any equipment read and understand the instructions.

- **Grounding Instructions** - This tool must be grounded while in use to protect the operator from electric shock. The tool is equipped with an approved three conductor cord and three prong grounding type plug to fit the proper grounding type receptacle. The green (or green and yellow) wire is the grounding wire.
- **Extension Cords** - Use only three wire extension cords which have three prong grounding type plugs and three pole receptacles which accepts the tool's plug. Replace or repair damaged cords.
- **Keep Work Area Clean** - Clean benches and floors to prevent slip, trip, or falls.
- **Consider Working Environment** - Don't use power tools in damp or wet locations. Keep work area well lit. Don't expose power tools to rain.
- **Do not use tool** in presence of flammable liquids or gases.
- **Keep Children Away** - All visitors should be kept a safe distance from the work area. Do not let visitors have contact with the tool or the extension cord.
- **Store Idle Tools** - When not in use, tools should be stored in dry, high or locked-up places out of reach of children.
- **Do Not Force Tool** - It will do the job better and safer at the rate for which it was designed.
- **Do Not Over-Reach** - Keep proper footing and balance at all times
- **Use Safety Glasses** - Also face or dust mask-wrap around goggles, or other eye protection.
- **Wear Proper Apparel** - Do not wear loose clothing or jewelry that can get caught in moving parts. Gloves and non-skid footwear are required when working. Wear protective hair covering to contain long hair.
- **Do Not Abuse Cord** - Never carry tool by cord or pull it to disconnect from receptacle.
- **Keep cord away** from heat, oil, and sharp edges.
- **Disconnect Tool** - When not in use; before servicing; when changing grinding wheels.
- **Avoid Accidental Starting** - Don't carry plugged in tool. Be sure switch is off when plugging in.
- **Grinding Wheels** - Use only grinding wheels having a maximum operating speed of 5500 RPM.
- **KEEP GUARDS IN PLACE.**
- **Guard Against Electrical Shock** - Prevent body contact with grounded surface. For example: pipes, radiators, etc.
- **Stay Alert** - Watch what you are doing. Use common sense. Do not operate tool when you are tired, or under the influence of any drugs or alcohol.
- **Check Damaged Parts** - Before further use of the tool, a guard or other part that is damaged should be carefully checked to determine that it will operate properly and perform its intended function.
- **Check for alignment** of moving parts, breakage of parts, mounting and any other condition that effect its operation. All parts should be properly repaired or replaced. Do not use this tool if the switch does not turn it on or off.
- **Never Leave Tool Unattended** - Turn the power off. Don't leave the tool until it comes to a complete stop.
- **Read "A Primer on Grinding Wheel Safety"** <http://www.magna-matic.com>

# SAFETY LABELS

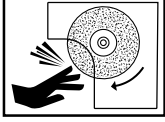
SAFETY COLOR	DEFINITION
 <b>DANGER</b>	Interaction with the hazard will cause severe injury or death.
 <b>WARNING</b>	Interaction with the hazard could cause severe injury or death.
 <b>CAUTION</b>	Interaction with the hazard could cause minor or moderate injury.

SAFETY ICON	DEFINITION
 <b>WARNING</b> 	
	Read all included manuals and bulletins included with this equipment.
	Always wear protective gloves when operating this equipment.  Gloves are required.
	Always wear protective eye wear when operating this equipment.  Eye protection required.
	Always wear protective hearing protection when operating this equipment.  Hearing protection required.
	Always wear respiratory protection when operating this equipment.  Respiratory protection required.

SAFETY ICON	DEFINITION
 <b>DANGER</b> 	Keep clear of the grinding wheel. Contact will cause severe cuts or abrasions.  Always keep safety guards in place.
 <b>DANGER</b> 	Disconnect power before servicing machine  Always keep safety panels in place.
 <b>WARNING</b> 	Keep clear of pulleys and belts. Contact will cause severe injury.  Always keep safety guards in place.

## QUICK START VIDEOS



# ASSEMBLY & TESTING



## CAUTION

TURN OFF  
AND UNPLUG  
BEFORE SERVICING!

### GRIT GUARD ASSEMBLY

1. Use #10 self-tapping screws to assemble the grit guard.
2. Start with the sides, they only fit one possible way, check that the holes line up.
3. The grit guard sides fit on the inside of the lips.
4. Assemble the grit guard bottom to the top and sides plates
5. The grit guard bottom three lips fit on the outside of the grit guard box.

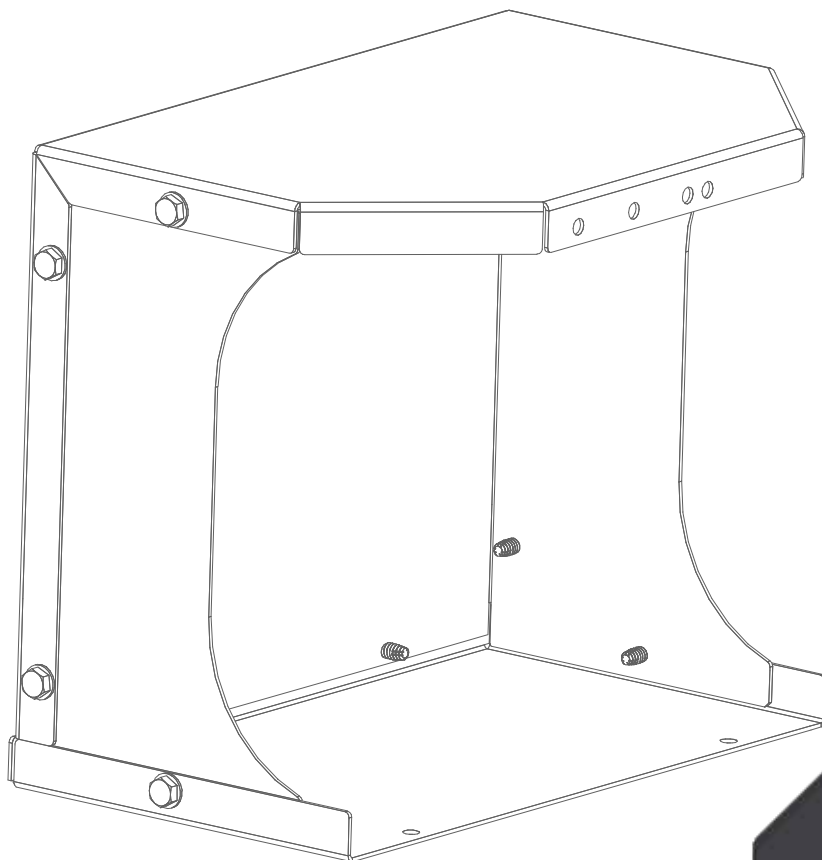

QUICK START  
VIDEOS

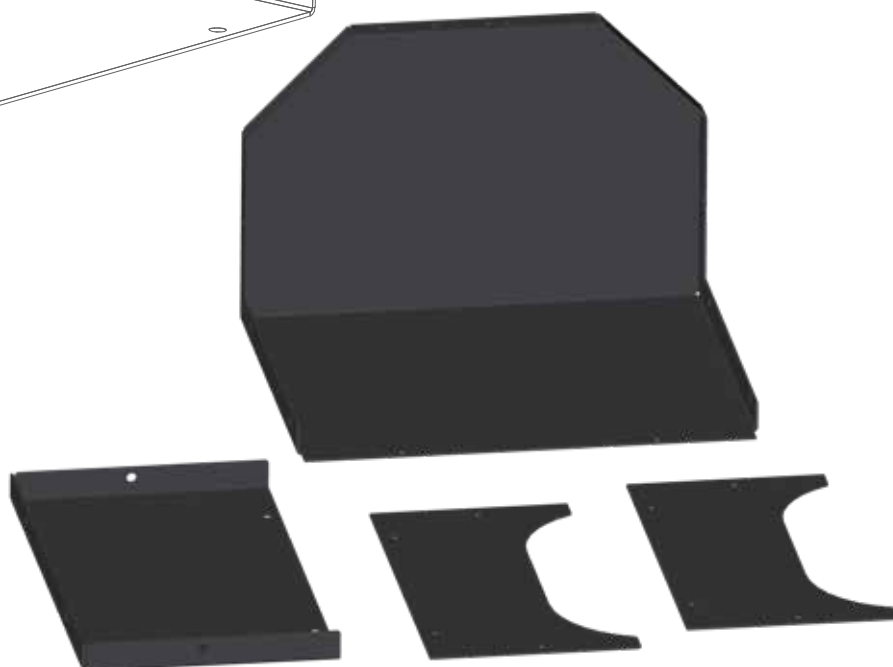

# ASSEMBLY & TESTING

## GRIT GUARD TO SHARPENER ASSEMBLY

1. Remove grinding wheel (see page 8-9)
2. Align the bottom of the grit guard to the yellow base of the sharpener. The bottom of the grit guard should cradle the yellow base.
3. Use two #10 self-tapping screws to connect the grit guard bottom to the sharpener
4. By doing this step first it will be easier to see which holes line up with the top of the grit guard and the yellow grinding wheel compartment.
5. Use two button head screws from the inside of the grinding wheel compartment, use the two nylon nuts to connect the top of the grit guard to the grinding wheel compartment.

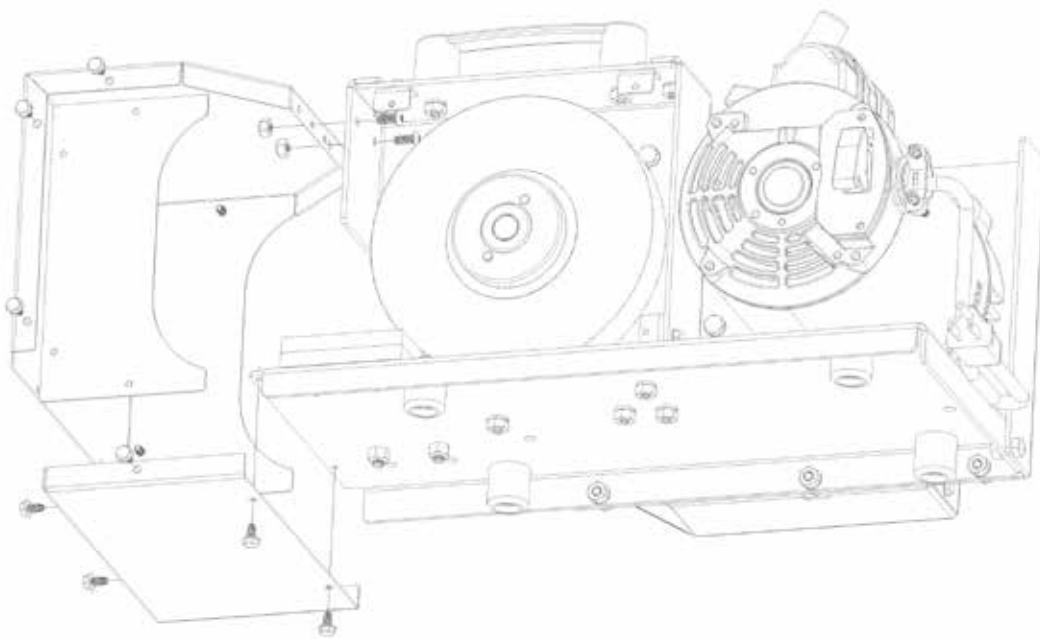

## WARNING

WHEN USING ELECTRIC TOOLS, BASIC SAFETY PRECAUTIONS SHOULD ALWAYS BE FOLLOWED TO REDUCE THE RISK OF FIRE, ELECTRIC SHOCK, AND PERSONAL INJURY.

## TESTING THE MAG-8100

Before turning the unit on, test the unit by checking if the grinding wheel moves freely. Ensure the MAG-8100 ON/OFF switch is in the OFF POSITION, plug the MAG-8100 into a 15 amp, 110 volt outlet. Switch the ON/OFF switch to the ON POSITION to test the motor. The motor should achieve FULL speed in 1-2 seconds. If it does not, (see page 15) or contact MAGNA-MATIC (800-328-1110).

# ASSEMBLY

## MOUNTING AND CHANGING GRINDING WHEELS

1. Be sure the MAG-8100 power cord is unplugged.
2. Use the two catch clamps to remove the black front cover.
3. Locate your spanner wrench and arbor wrench (both supplied by Magna-Matic.)
4. The arbor wrench fits into a square notch in the arbor behind the grinding wheel
5. The spanner wrench fits into the two holes in the arbor nut.
- 6. ARBOR HAS LEFT-HANDED THREADS.**

Always inspect grinding wheels for possible damage - never mount a cracked grinding wheel.  
**DO NOT OVER-TIGHTEN ARBOR NUT - ONLY LIGHT PRESSURE TO TIGHTEN.**  
The motor will tighten the arbor nut every time the sharpener is turned on.

For optimum performance use only grinding wheels specified by Magna-Matic. All NORTON® brand grinding wheels sold by Magna-Matic are speed tested for 5500 RPM

**NOTE: ARBOR HAS LEFT-HANDED THREADS.**

**MAG-8100 OEM 1" WHEEL = 9000-23**

**Purchase replacement grinding wheels at:**  
<https://www.magna-matic-direct.com/grinding-wheels/>

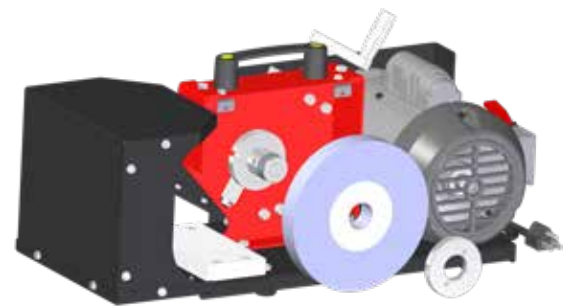

Scan Here to buy  
abrasives



**STRAIGHT FLAT  
CUTTING EDGES**

**CURVED / WAVY  
CUTTING EDGES**



# STAND SET-UP

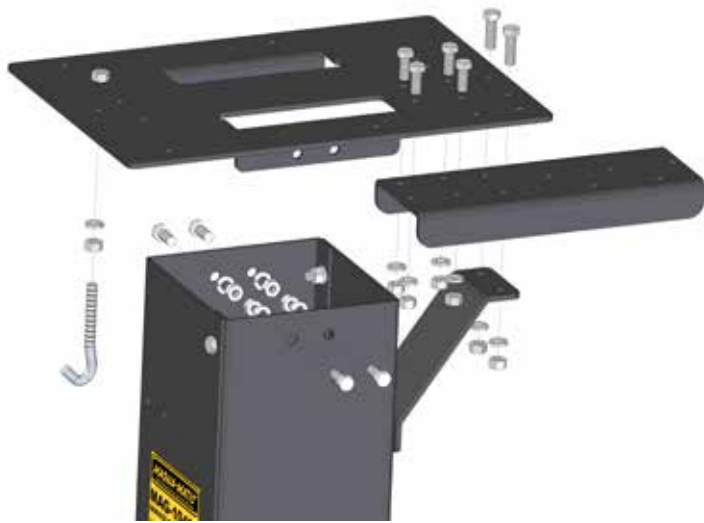

The table top orientation for the MAG-10400 stand for all MAG-8000, MAG-8100, and MAG-8200 Sharpeners. This is covered in Step 7 of the stand instruction sheet.

Use two 1/4-20 x 2" long hex bolts with 1/4 nuts to directly mount the MAG-8100 directly to the stand table top.

## IMPORTANT STAND NOTE:

The MAG-8100 Series mounts in the same orientation as the MAG-8000. So when you follow your MAG-10400 Stand instructions "STEP 7".

The black base of the MAG-8100 is not threaded so the mounting to the stand is with a through bolt 1/4".

The 10400-04 balancer arm base is a little longer now for the new MAG-8100 series.

## IMPORTANT DUST COLLECTOR NOTE:

The MAG-8100 Series mounts needs the MAG-200 Dust Collector mounted under the grit guard.

It is mounted on the opposite side that it was for the MAG-8000.

For the MAG-8100 we have increased to a 4" diameter grit guard inlet and 4" diameter yellow spiral hose. This increases the air flow up 400 CFM from 250 CFM.

**Call with any questions!**  
**800-328-1110**



MAGNA-MATIC®

# ANGLE ADJUSTMENT



## WARNING

WHEN USING ELECTRIC TOOLS, BASIC SAFETY PRECAUTIONS SHOULD ALWAYS BE FOLLOWED TO REDUCE THE RISK OF FIRE, ELECTRIC SHOCK, AND PERSONAL INJURY.



## CAUTION

**TURN OFF  
AND UNPLUG  
BEFORE SERVICING!**

## 30 DEGREE ANGLE

**MOST BASIC ANGLE - READ FOLLOWING INFO!**

30 degrees is the most consistent and easiest angle to maintain in the MAG-8100. It is the industry average angle on most blades. If you are looking for the most simple way to consistently sharpen your lawn mower blades, use 30 degrees according to following instructions.

### ANGLE ADJUSTMENT

Turn off the sharpener. Lower the grinding wheel by using the aluminum crank handle within a 1/32" from the worktable. You want to get the grinding wheel as close as possible to the white worktable. The thickness of a business card is a good gage too.

As the grinding wheel wears continue to lower the wheel to maintain this closeness to the worktable. By doing this you will maintain 30 degrees on all your cutting edge angles of your lawn mower blades.

Do not lower the grinding wheel while the sharpener is ON. You risk grinding into the worktable which will make it more difficult to maintain your blade edge angles.

If you do accidentally grind into the worktable the MAG-8100 has an on-board replacement. There are two of the 8100-39 worktables stacked. If you top one wears out just swap bottom to the top position. Two worktables must be installed in the MAG-8100 or your blade will not be at the correct height to maintain 30 degrees. If you would like a larger worktable you can purchase two of part 8200-046 to have a 12" long worktable.

**Adjust wheel downward to adjust for wear or to change angles.**

**The grinding wheel must ALWAYS be lowered to the worktable to maintain 30 degrees.**



# GRINDING WHEEL REPLACEMENT



## CAUTION

LAWN MOWER BLADES HAVE SHARP EDGES - ALWAYS WEAR PROTECTIVE GLOVES AND SAFETY GLASSES!

Be sure the MAG-8100 power cord is unplugged. Using a 5/16" socket wrench remove the (3) screws of the front steel guard. Locate your spanner wrench and arbor wrench (both supplied by Magna-Matic.) The arbor wrench fits into a square notch in the arbor behind the grinding wheel, and the spanner wrench fits into the two holes in the arbor nut. See diagrams below.

Always inspect grinding wheels for possible damage - never mount a cracked grinding wheel. **DO NOT OVER-TIGHTEN ARBOR NUT - ONLY LIGHT PRESSURE TO TIGHTEN.** The motor will tighten the arbor nut every time the sharpener is turned on.

For optimum performance use only grinding wheels specified by Magna-Matic. All NORTON® brand grinding wheels sold by Magna-Matic are speed tested for 5500 RPM

**NOTE: ARBOR HAS LEFT-HANDED THREADS.**

**OEM WHEEL 1" WIDE = 9000-23**

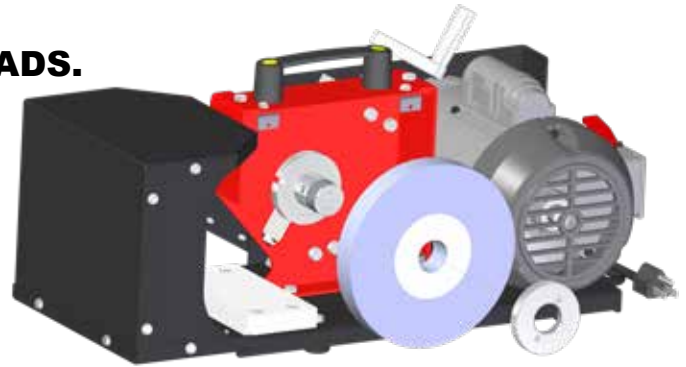

Scan Here to buy abrasives

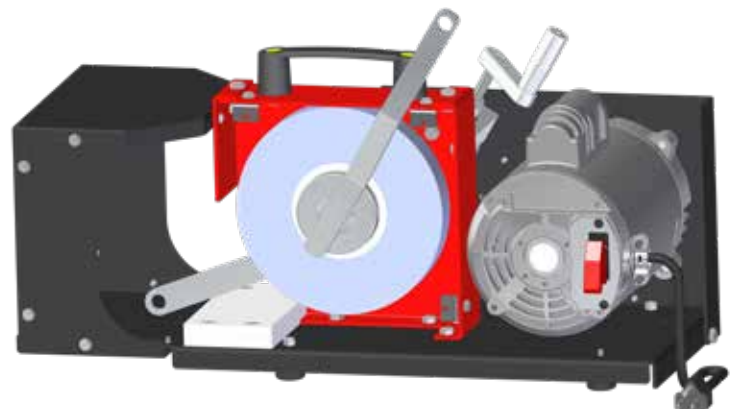
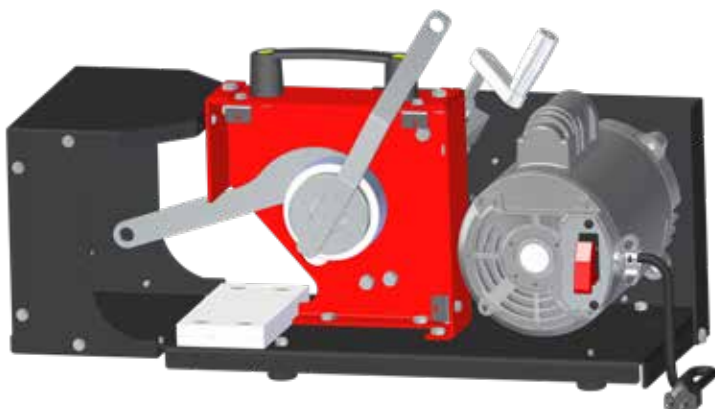
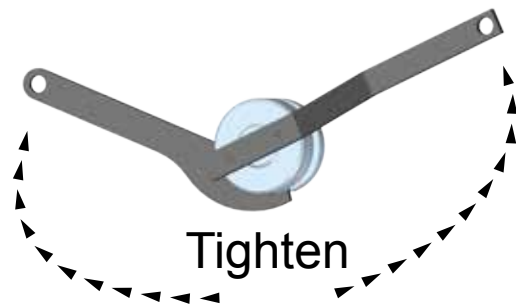
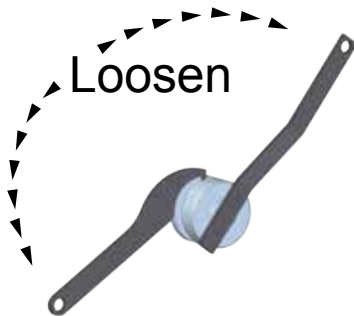

MAGNA-MATIC®

# CONVENTIONAL BLADES



## CAUTION

LAWN MOWER BLADES HAVE SHARP EDGES - ALWAYS WEAR PROTECTIVE GLOVES AND SAFETY GLASSES!

### SHARPENING A LAWN MOWER BLADE

Be sure to wear protective clothing while handling and sharpening lawn mower blades. Wear safety glasses and protective gloves. Always deburr the underside of the blade, prior to sharpening the blade.

### BLADE & SHARPENER PREPARATION

1. Clean the blade to its base material, using the MAG-12008 blade cleaner, or alternate cleaning process. Inspect the blade for fractures. (**never weld mower blades**)
2. Check the straightness with the gauge rod of the MAG-1000 blade balancer (**never straighten bent blades**)
3. Obtain a balance reading from the MAG-1000 to indicate the light end of the lawn mower blade. Once the light end is sharpened, that end is complete. The heavy end is used to remove material for balance. See MAG-1000 instructions for more details on blade balancing. (**never weld mower blades**)
4. Adjust the cutting edge angle to 30 degrees.

### CONVENTIONAL BLADE SHARPENING

1. Switch the ON/OFF switch to ON position
2. Place the conventional blade on the worktable, you should push and pull the blade across the grinding wheel. Notice approach the grinding wheel as shown.
3. Stay perpendicular to the rotation of the wheel.
4. Keep firm downward pressure on the top of the blade so that contact is maintained with the worktable. This is important because the angle is referenced off the worktable and underside of the blade.
5. The force into the grinding wheel should be substantial resulting in a continuous stream of sparks and a deep smooth grinding sound.
6. The grinding process should be continuous without interruption until finished.

### IT IS TAKING A LOT OF GRINDING TO GET A SHARP BLADE?

*Are the grinding marks on the “trailing edge” (top edge) of the mower blade cutting edge?*

That means your blades were at a steeper angle than you are grinding now. If your blades were previously sharpened with some other method it is very likely your cutting edge angles are near 45 degrees. It is very common for blades sharpened on other machines or with an angle grinder to be way up at 45 degrees or steeper. This often happens when people “free-hand” grind.

The MAG-8200 is going to make a consistent 30 degree angle - so your first grinding may take much longer and use more of the grinding wheel because you are re-machining your blades. This correction requires a lot of steel be removed to go from 45 down to 30 degrees.

Don't worry, once fix all your blades and make them 30 degrees, every sharpening after that will be very fast because you will grind a consistent angle every time from now on with your MAG-8200.

Keep constant pressure downward to maintain flat contact with the blade underside and worktable.

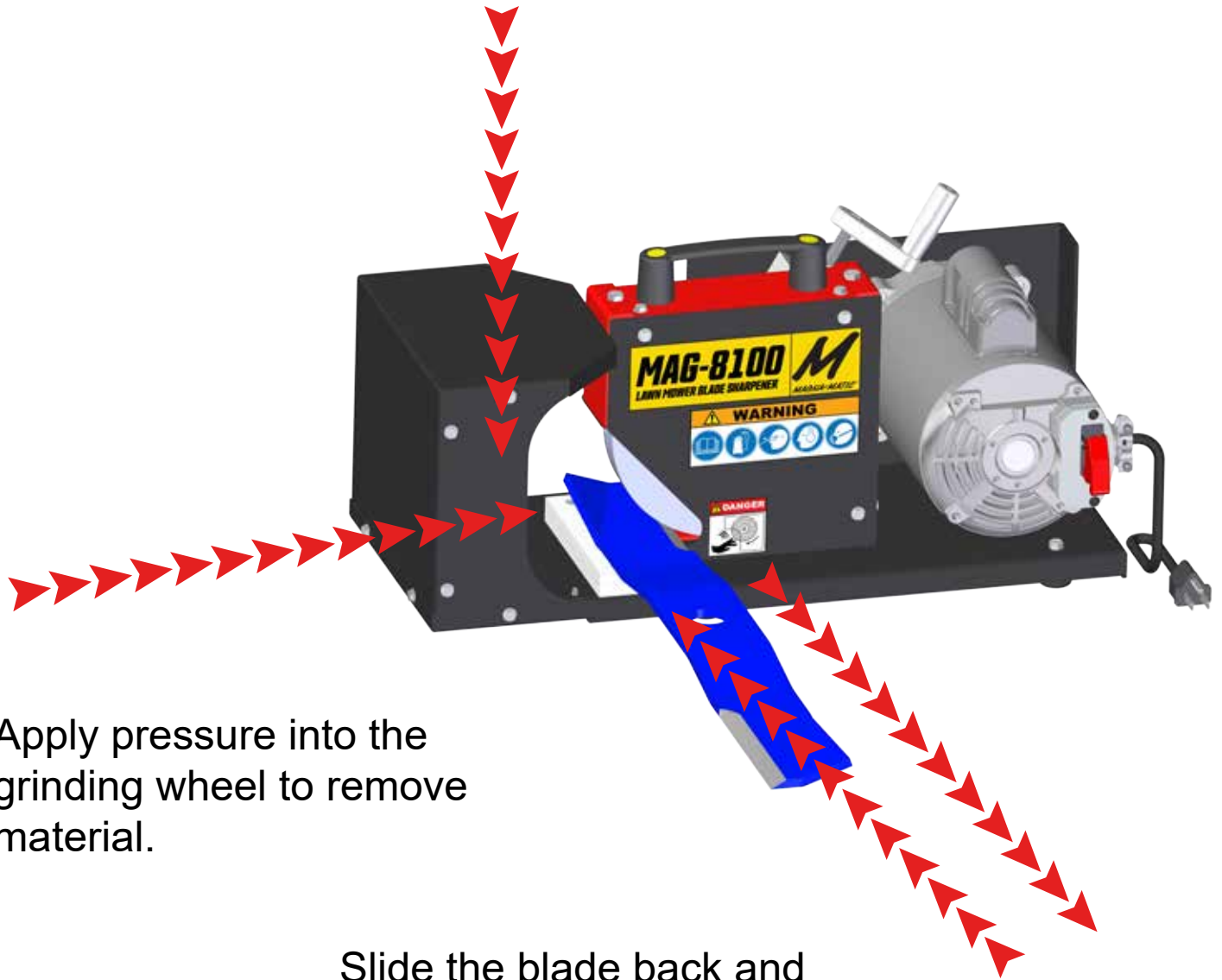

Apply pressure into the grinding wheel to remove material.

Slide the blade back and

***MAG-8100 Sharpener  
Overhead-View***

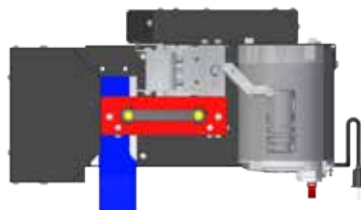

***Right-Handed  
Blade***

***Left-Handed  
Blade***

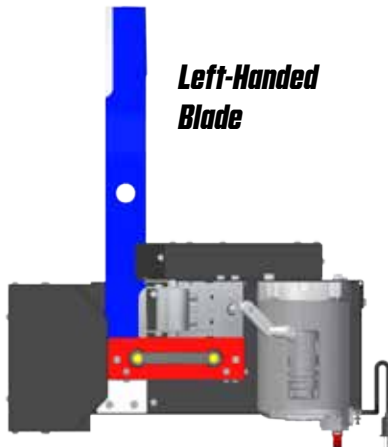

# MAG-8100 SERVICE & CARE



## CAUTION

LAWN MOWER BLADES HAVE SHARP EDGES - ALWAYS WEAR PROTECTIVE GLOVES AND SAFETY GLASSES!

### GENERAL CARE:

Keep the MAG-8100 clean, use compressed air to blow the machine off periodically.

### POLY-V BELT REPLACEMENT & ADJUSTMENT

- Unplug the sharpener from power source.
- Remove the steel pulley cover, 6 screws (5/16" wrench or socket)
- Remove the old belt.
- First put the belt over the grinding wheel pulley.
- Next put the belt on the smooth part of the idler pulley
- Pull the belt over the motor pulley, on to the smooth part.
- By pulling on the belt you will compress the idler pulley.
- Now rotate the pulleys and push the belt over to get all the little ribs of the belt into the grooves in the pulleys.
- Ensure all 6 ribs are seated in all 3 pulleys, and rotate the pulleys by hand to check.

The poly-V belt is always under proper tension by the idler pulley.

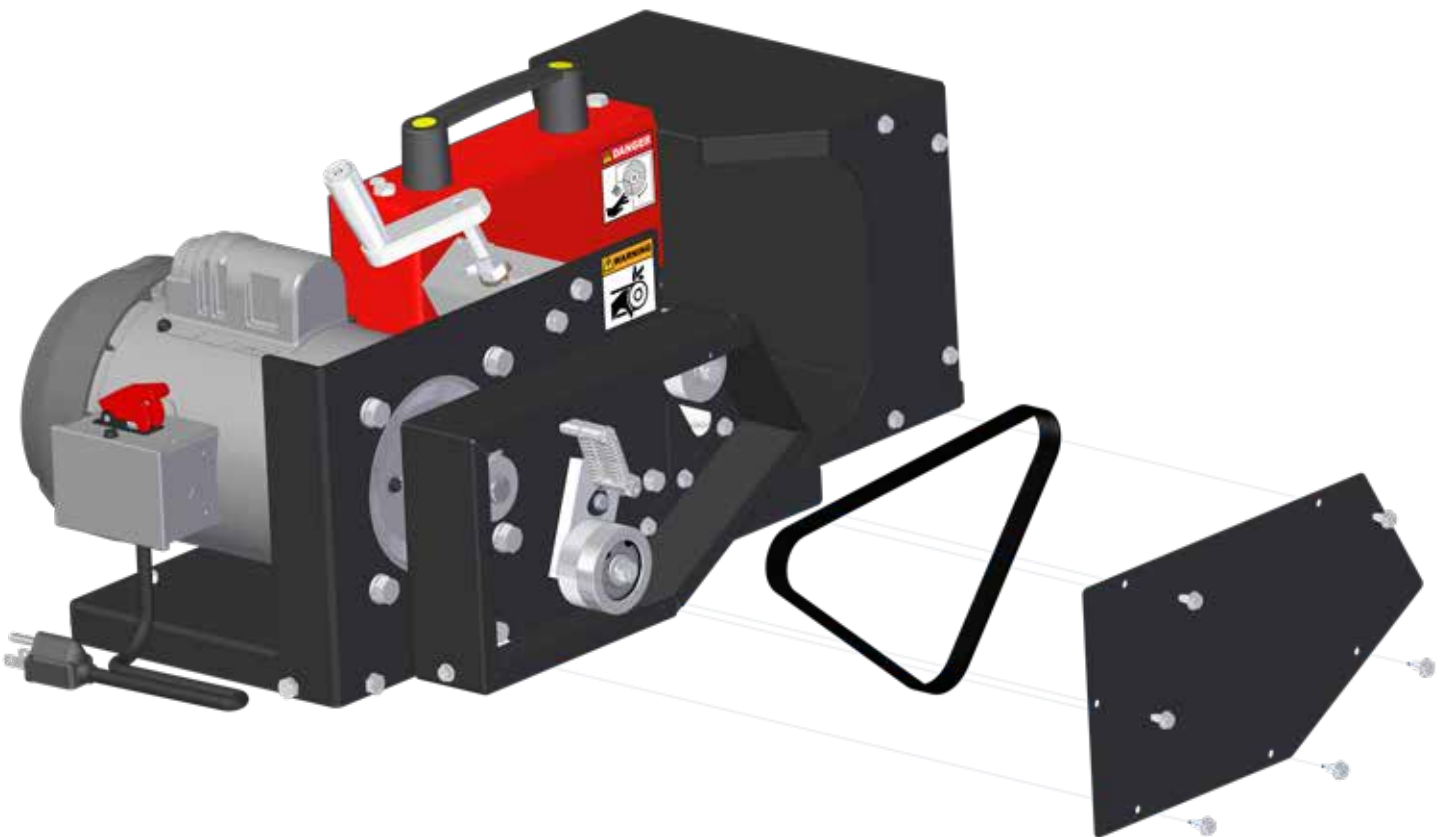

# TROUBLESHOOTING

PROBLEM	CAUSE	SOLUTION
Motor fails to start	Fan guard bent/damaged and contacting fan.	Replace fan guard
Motor has been running, then fails to start	Fuse or circuit breaker tripped.	Replace fuse or reset the breaker.
Motor has been running, then fails to start	Motor overloaded or load jammed.	Inspect to see that the load is free. Verify amp draw of motor versus nameplate rating.
Motor has been running, then fails to start	Capacitor may have failed.	First discharge capacitor. To check capacitor, set volt-ohm meter to RX100 scale and touch its probes to capacitor terminals. If capacitor is OK, needle will jump to zero ohms, and drift back to high. Steady zero ohms indicates a short circuit; steady high ohms indicates an open circuit.
Motor has been running, then fails to start	Starting switch has failed.	See wiring diagram and connect the black wire from the motor and the black wire from the cord to bypass the switch.
Motor runs but dies down	Voltage drop	If voltage is less than 10% of the motor's rating contact power company or check if some other equipment is taking power away from the motor. If motor is run using an extension cord, verify that this extension cord is properly sized for motor's current draw.
Motor takes too long to accelerate	Defective capacitor	Test capacitor per previous instructions.
Motor takes too long to accelerate	Bad bearings	Noisy or rough feeling bearings should be replaced.
Motor takes too long to accelerate	Voltage too low.	Make sure that the voltage is within 10% of the motor's nameplate rating. If not, contact power company or check if some other equipment is taking power away from the motor.
Motor overload protector continually trips	Ambient temperature too high.	Verify that the motor is getting enough air for proper cooling. Most motors are designed to run in an ambient temperature of less than 40°C. (Note: A properly operating motor may be hot to the touch.)
Start capacitors continuously fail.	Voltage to motor is too low.	Verify that voltage to the motor is within 10% of the nameplate value. If the motor is rated 110-125 V, the deviation must be calculated from 125 V.
MAG-8100 is vibrating	Grinding wheel is out-of-round	Dress the wheel and old lawn mower blade. Use a perfectly flat area, like around the mounting hole. Place it in the sharpener like you would normally, and slowly apply pressure into the wheel. Do not go back and forth, just apply even pressure, and let the wheel true itself.
MAG-8100 is vibrating	Bad motor bearings	Remove the grinding wheel, and run the MAG-8100. Inspect the motor shaft and bearings.
MAG-8100 is vibrating	Loose pulleys or bearings	Tighten set screws, locking agent should be used.
MAG-8100 is vibrating	Poor belt tension	Check idler pulley springs
MAG-8100 is vibrating	Bad drive shaft bearings	Check and replace the two spindle bearings
MAG-8100 crank will not adjust the wheel up or down	Adjustment truck is jammed	Inspect the adjustment truck and guide rods for foreign material, clean.
Unable to remove grinding wheel	Turning wrong direction	The arbor nut has left-handed threads. Turn clockwise to loosen. Use both the arbor and spanner wrench.
Difficult to remove grinding wheel	Extremely tight, wheel has not been changed in a long time.	Using both the spanner and arbor wrenches, Allow the arbor wrench to stop against the yellow body, Use a plastic hammer and tap the end of the spanner wrench, imparting vibration will shock the nut loose. In extreme situations you can apply heat, only to the arbor nut. Last resort, you can break the wheel off the arbor.

# Blade Tip Geometry.

## What part of a rotary lawn mower blade cuts the grass?



Training Video

It is a common misconception that lawn mower blades cut like a knife. It actually has more in common with the way circular saw teeth cut. The confusion comes from the two shapes; a lawn mower blade looks like a rectangle, and the circular saw is a circle. Keep in mind that when the lawn mower blade is in motion it is also a circle. The primary difference is that a circular saw is for wood or metal. Because these materials are much more dense, more cutting teeth are required. Turf is considerably less dense than wood or steel so only two teeth are required.

The tips of the blade do the majority of the cutting work; they are the cutting teeth of the blade. Repeated observation of worn cutting edges show that the first 1-2 inches do the majority of the cutting. To produce a cutting tip, three relief angles are necessary.

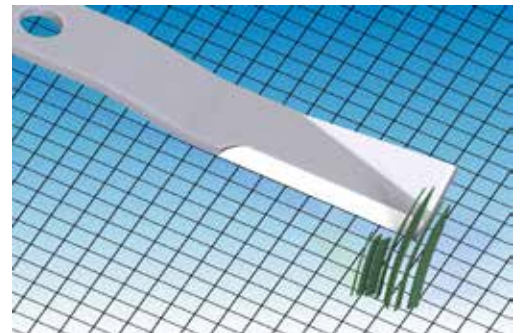

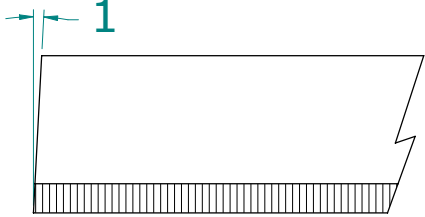
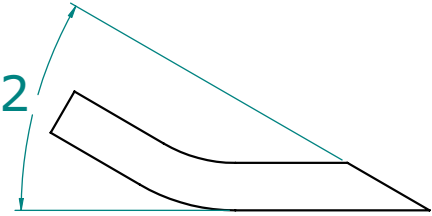
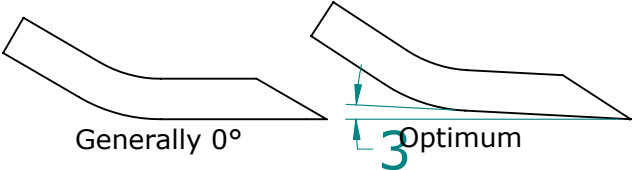
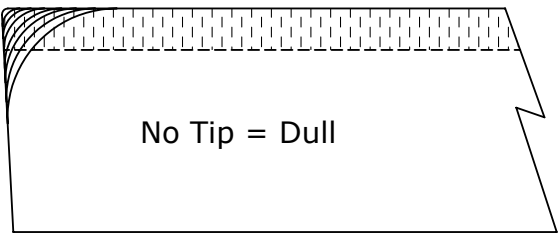
Description	Diagram
<p><b>Relief Angle One:</b></p> <p>Top view - built into the blade (generally 2-5 degrees)</p>	
<p><b>Relief Angle Two:</b></p> <p>End view - To be re-sharpened (industry average is 30°)</p>	
<p><b>Relief Angle Three:</b></p> <p>End view - built into the blade</p>	
<p><b>Top View of Blade Land-side:</b> Worn Blade Edge</p> <p>Worn away bottom surface at tip. As shown, is a sign of poor blade maintenance. The blade will tear the grass, resulting in a poor looking lawn.</p>	



# Understanding the Rotary Lawn Mower Blade

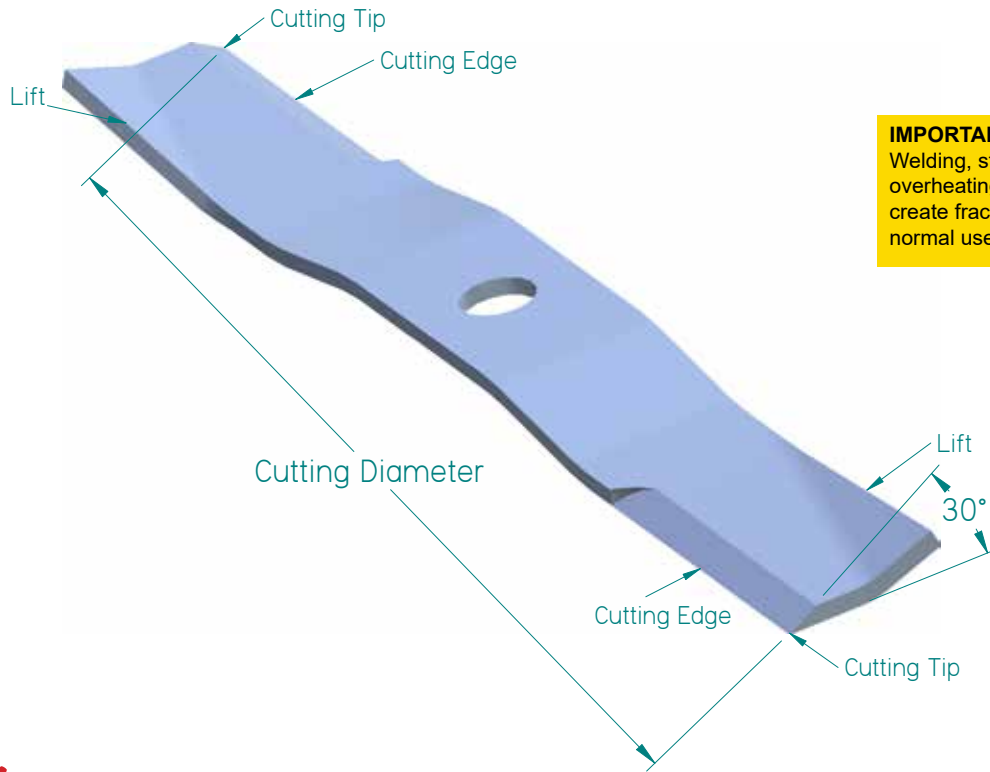

**IMPORTANT NOTES:**  
Welding, straightening, sharp corners, and overheating the lawn mower blade may create fractures that break the blade under normal use and may cause injury.



Training Video

## SAFETY

The first 1-2 inches of any lawn mower blade do the majority of the cutting work and take the most wear. This is where the most grinding is required to reproduce a cutting tip again.

Often people think that the full cutting edge must be ground back parallel to the rest of the blade. This is not necessary and can create a dangerous fracture point if done (see image #2). Image #1 shows the over-head view of the blade that, over the life of the blade will become “tapered looking” from wear and re-sharpening. This follows the natural wear pattern of a rotary lawn mower blade’s use. We recommend this method because less steel is removed. Leaving more steel there will help prevent a fracture that could discharge a part of the blade from the deck.

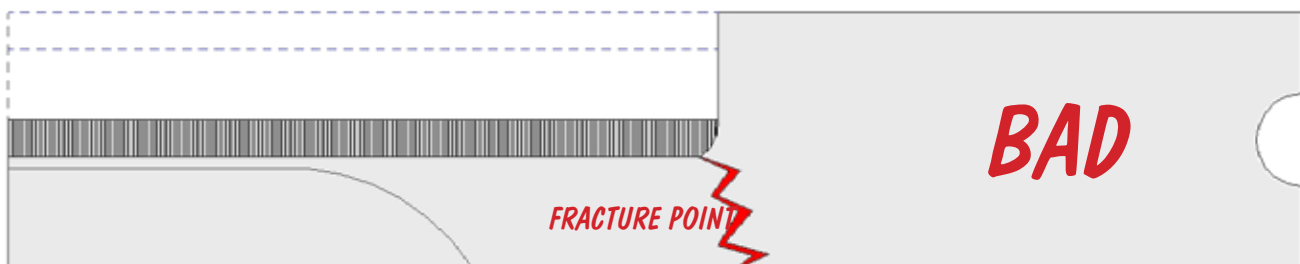
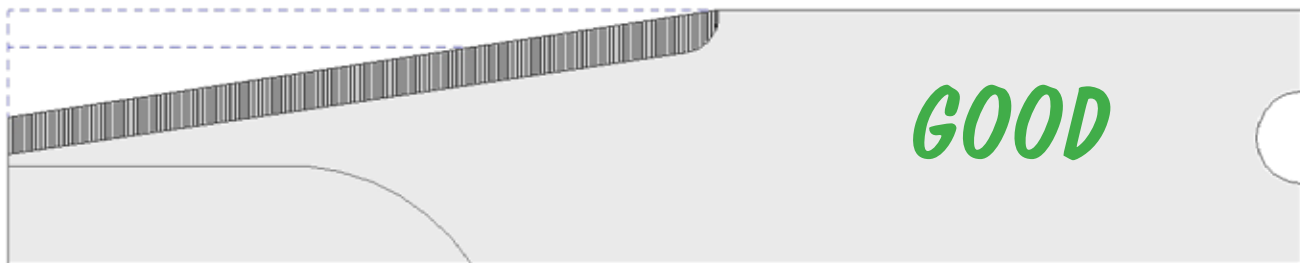

MAGNA-MATIC®

# MAG-8100 PARTS KEY

KEY #	PART NUMBER	DESCRIPTION	QUANTITY
1	8100-23	Front grinding wheel cover	1
2	H-10C0375TSWZ/F	#10-24 X 3/8 HEX HEAD SELF TAPPING SCREW TYPE F	30
3	9000-19	Arbor nut	1
4	9000-23	Grinding wheel 7"x1"x1-1/4" soft	1
5	9000-20	Arbor	1
6	8100-01 or 200-19	8100-01 is the 1/3 HP motor and 200-19 is the 1/2 HP motor option	1
7	8100-31	Cord retention	1
8	9000-54	ON / OFF toggle switch	1
9	200-18	Red switch cover	1
10	9000-12	Cord set	1
11	9000-58	Carry handle	1
12	H-37WLZ	3/8" lock washer	4
13	H-37C075HSZ	3/8"-16 x 3/4" hex screw	4
14	H-25C050KSD	1/4"-20 x 1/2" dog poitn set screw	2
15	8200-030	Motor pulley	1
16	8200-018	3/8" bronze washer	1
17	H-25C150SSZ	1/4"-20 x 1.50" long socket screw	1
18	8200-027	Drive belt tensioner plate	1
19	8200-008	1-3/8" internal retaining ring	2
20	8200-029	Idler pulley	1
21	8100-41	Idler bearing	2
22	8200-028	Drive belt tensioner shaft	1
23	H-25WFZ700	1/4" over-sized M6 washer	1
24	H-25WLZ	1/4" lock washer	1
25	H-25CNFZ	1/4"-20 nut	1
26	H-25N100KSS	1/4"-20 x 1.00 shoulder bolt	1
27	8100-27	Pulley inside cover	1
28	8100-25	Pulley cover bottom	1
29	8100-42	Drive belt	1
30	8100-26	Pulley cover	1
31	8200-033	Tensioner plate pivot	1
32	8200-016	Curved spring washer	1
33	8200-011	3/8" external retaining ring	1
34	8200-031	Drive shaft pulley	1
35	H-25WFZ700	1/4" over-sized M6 washer	1
36	H-25WLZ	1/4" lock washer	2
37	H-25C050HSZ	1/4"-20 x 1/2" long	12
38	8200-032	Spring holder	1
39	8200-013	Spring for belt tension	1
40	8100-24	Pulley cover top	1
41	8200-078	Grit guard bottom	1
42	8200-075	Grit guard top	1
43	8200-076	Grit guard sides	2
44	H-25CNINFZ	1/4"-20 nyloc nut	4
45	8100-39	Worktable (standard size)	2
46	H-25C125PFZ	1/4"-20 x 1.25" long phillips screw	4
47	8100-28	Angle nut	3
48	9000-13	Crank handle base	1
49	9000-14	Crank handle	1

# MAG-8100 PARTS DIAGRAM

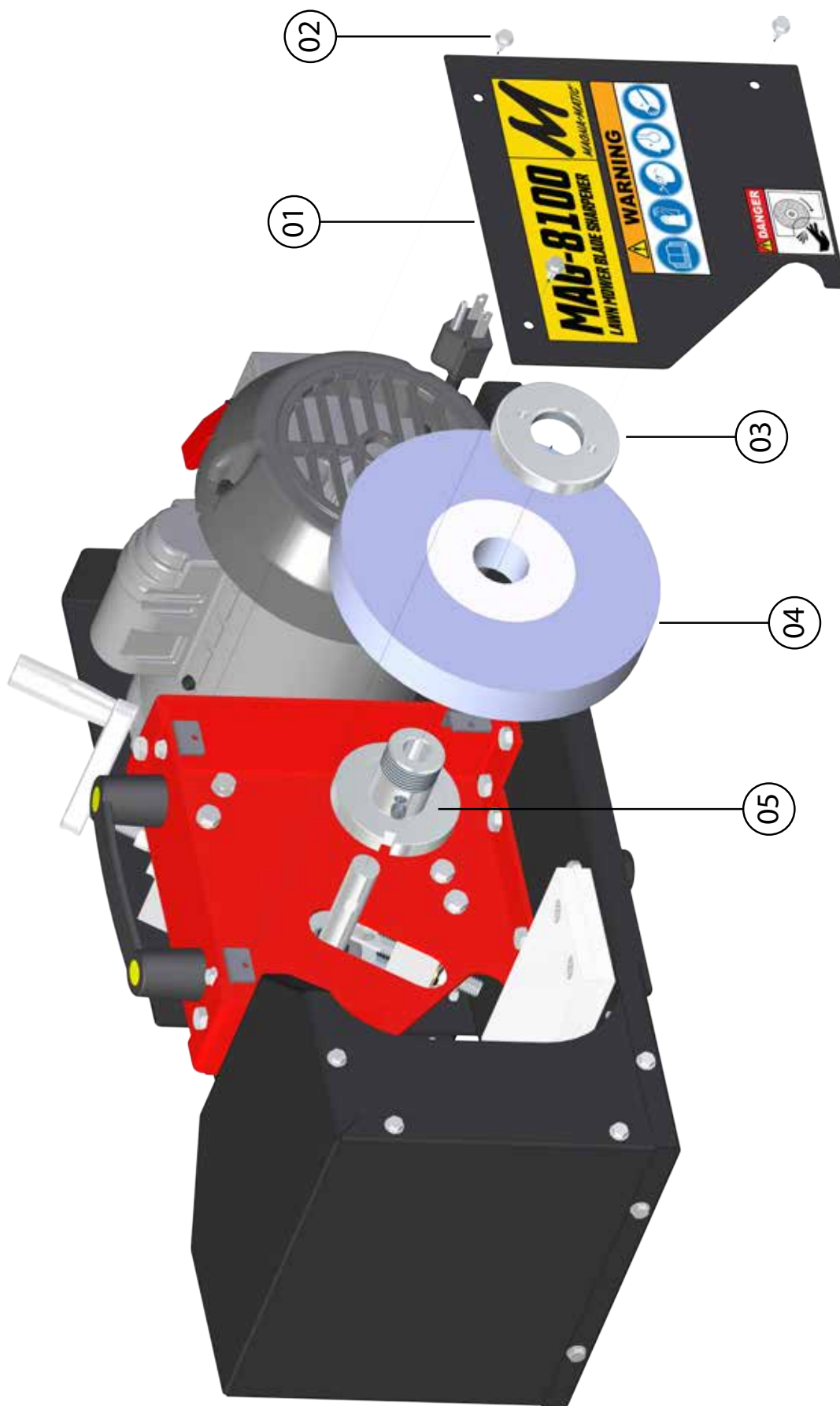

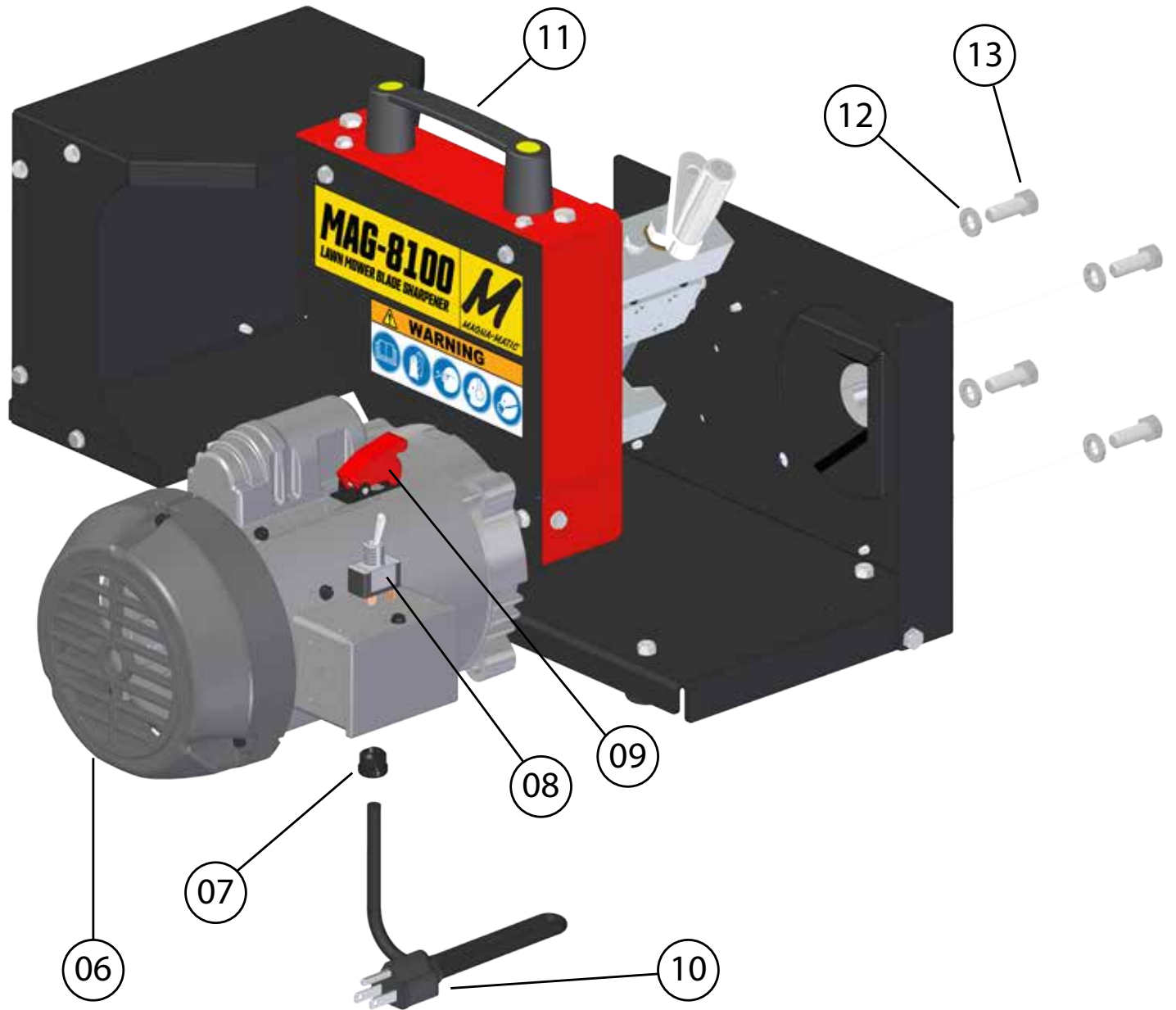

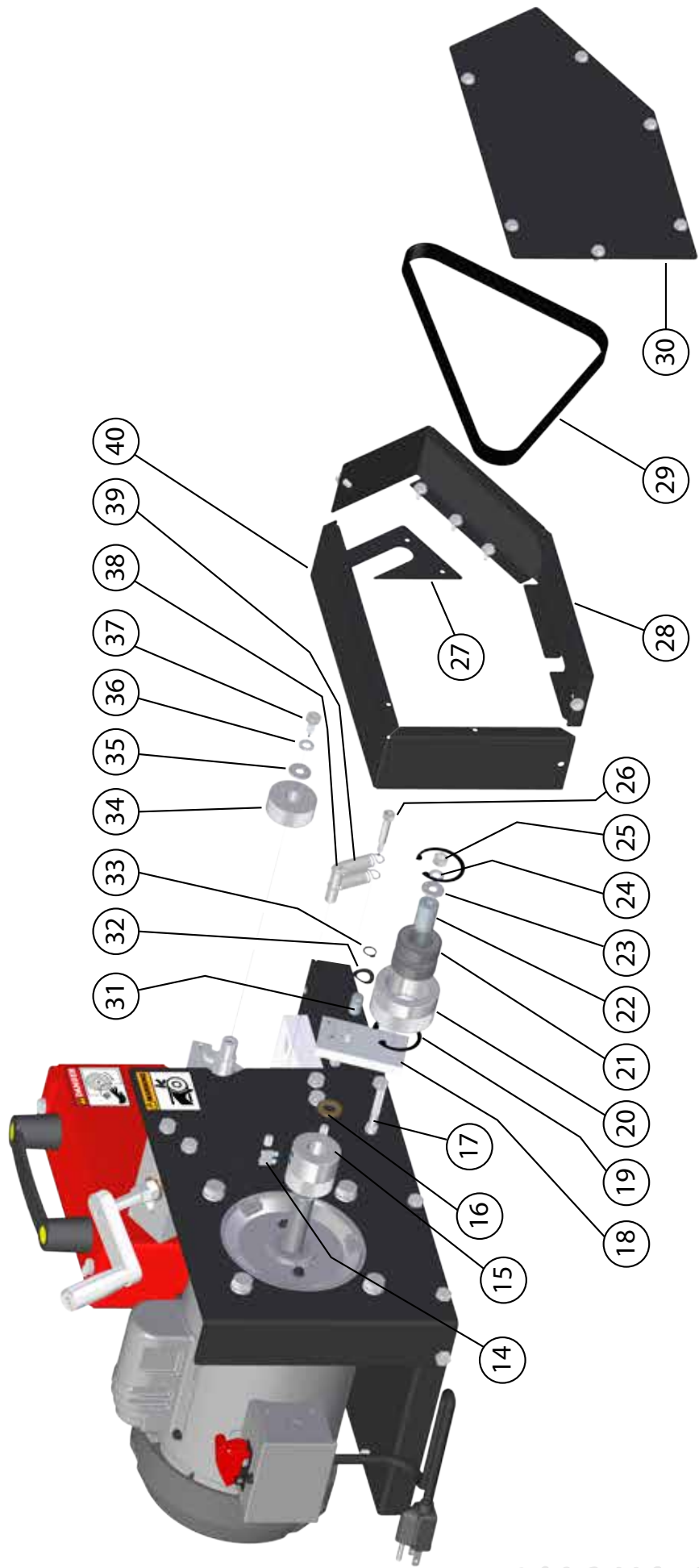

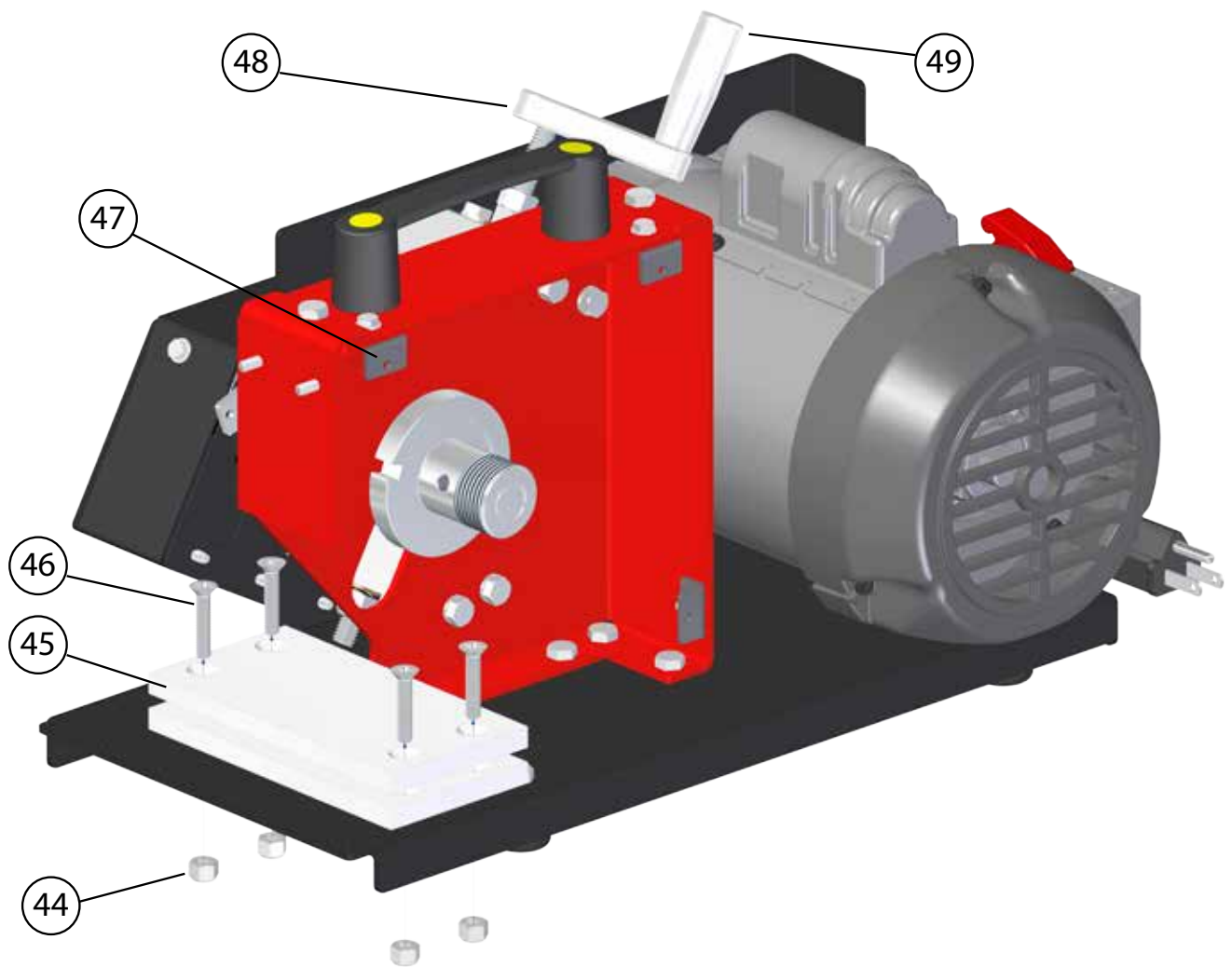
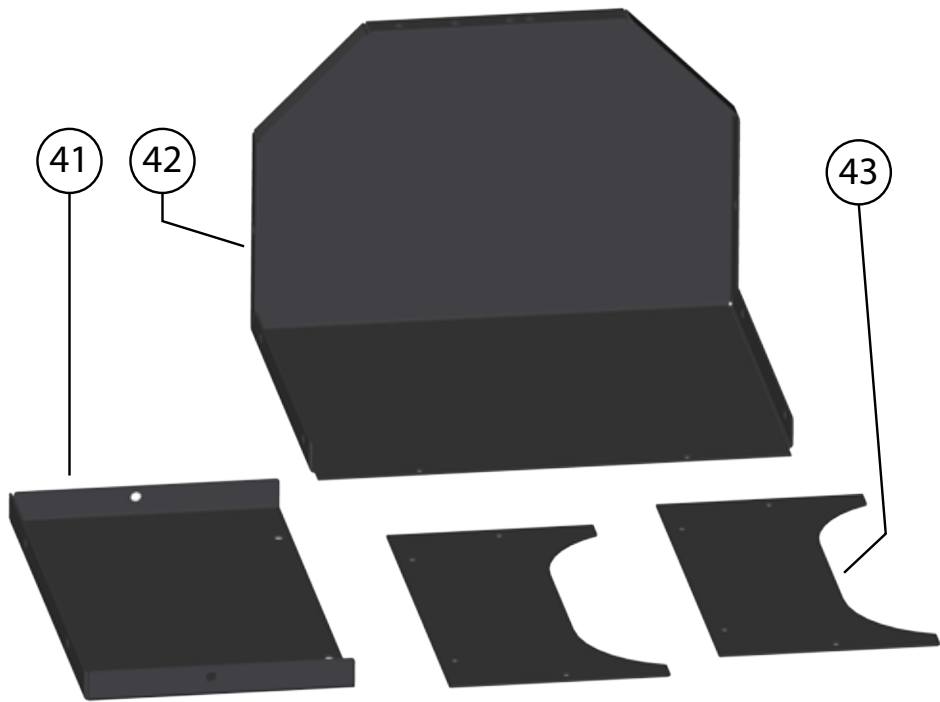

# EC03 - 1/2 HP & EC0332 1/3 HP

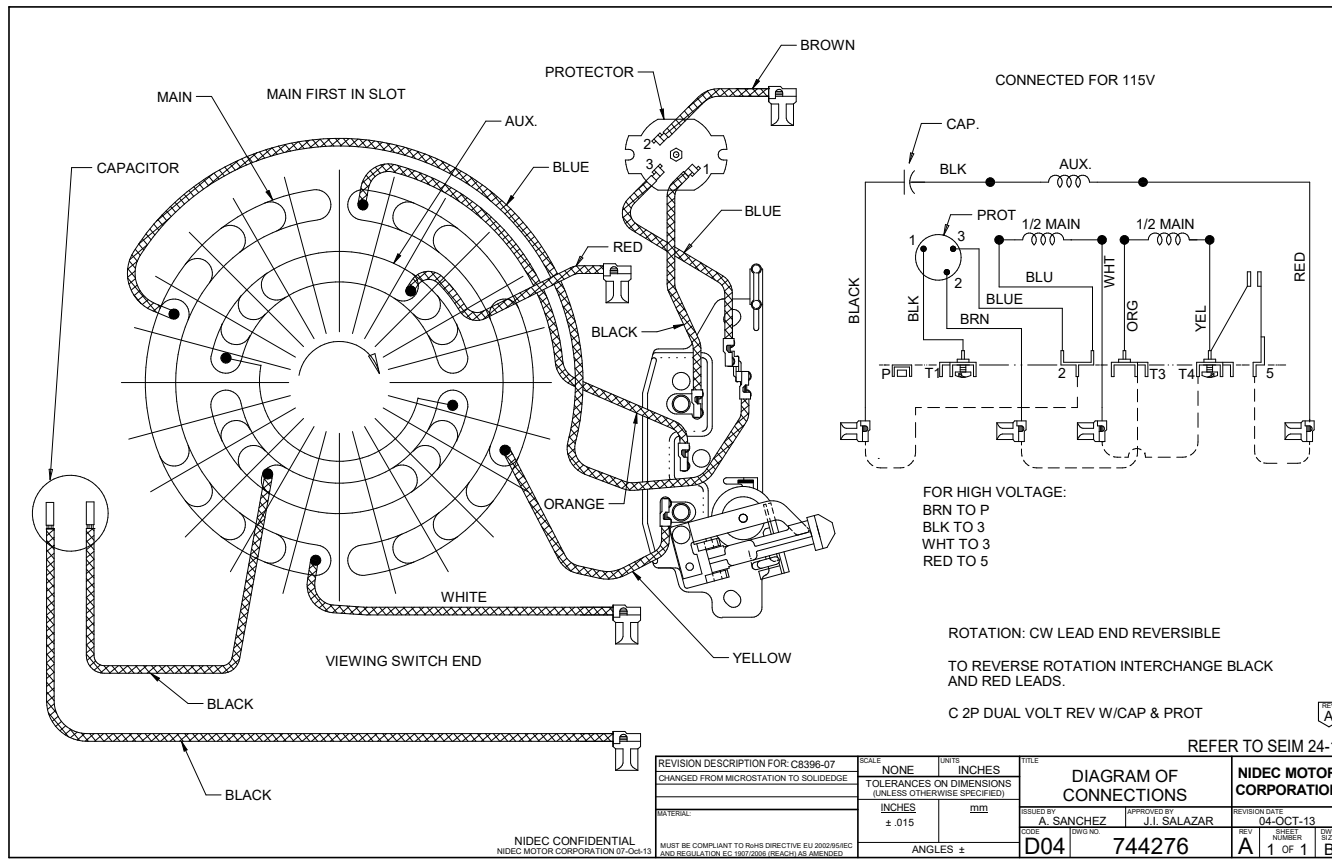

# T12CA1JCR - 1/2 HP

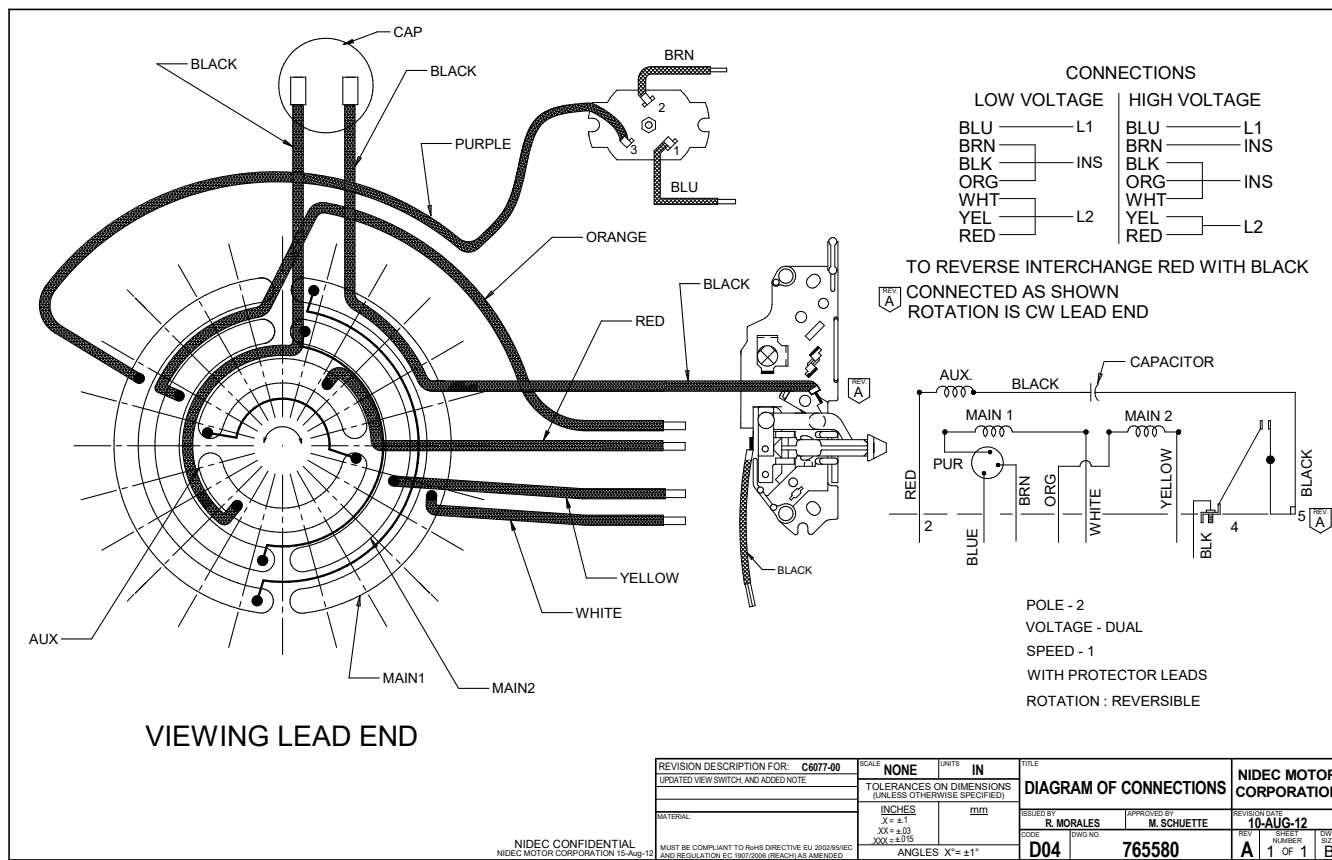

# WARRANTY

MAGNA-MATIC CORPORATION (the "Manufacturer") warrants Manufacturer's products (the "Products") will be free from defects in manufacture by Manufacturer (the "Warranty"). The Warranty will be effective and valid for a period of one (1) or two (2) years, as indicated on the Warranty certificate or Manufacturer's website (<http://www.magna-matic.com>), beginning on the date in which Manufacturer ships the Product (the "Warranty Period") from manufacturer's facility directly to Manufacturer's distributor or customer/end user (the "Customer"). The Warranty shall obligate Manufacturer to repair or replace (in Manufacturer's discretion) defective Products as provided below. Manufacturer shall maintain records, including Manufacturing Process Instructions, for all Products for a period equal to the Warranty Period. Upon the expiration of the Warranty Period, Manufacturer will have no further obligation to Customer with respect to a Product that is non-conforming and/or defective for any other reason.

To take advantage of the Warranty, Customer must take the following three steps: (1) Customer must promptly notify Manufacturer after Customer becomes aware that it has a defective Product, which in all events must be within thirty (30) days of Customer's discovery of the defect and within the Warranty Period; and (2) Customer must provide detailed digital pictures and/or must return the defective Product to Manufacturer immediately thereafter and/or make the Product available to Manufacturer for inspection (at Manufacturer's request/discretion), and in no event more than thirty (30) days after any notification provided in (1) above; and (3) Customer must insure the defective Product until Manufacturer receives and accepts it. After Customer has taken the above steps, Manufacturer will evaluate the Product to determine if Customer's warranty claim is valid and to determine what, if any, remedy is available to Customer. Customer must return or make available all defective Products with complete documentation associated with the defective Product.

The Warranty shall be invalidated if: (1) damage to the Product is the result of misuse or abuse by Customer or any end user of the Product; or (2) if the Product has been modified by Customer or any end user of the Product; or (3) if any defects in the Products are caused as a result of Manufacturer following Customer's specifications in manufacture that contain any problems, faults, errors, miscalculations, or discrepancies in the specifications. If Manufacturer decides to repair or replace the defective Product, Manufacturer will ship the repaired or replaced Product (both, a "Repaired Product") F.O.B. the shipping point and all of the provisions in this Warranty pertaining to the Products will apply to the Repaired Product, including but not limited to, the risk of loss provisions set forth above. Notwithstanding the prior sentence, the Warranty Period for a Repaired Product will not be restarted, but instead will expire at the same time as though the Repaired Product was never a defective Product but rather the Product at all times.

THE WARRANTY PROVIDED HEREUNDER IS THE ONLY WARRANTY MANUFACTURER PROVIDES TO CUSTOMER, AND SHALL BE IN THE PLACE OF ANY OTHER EXPRESS OR IMPLIED WARRANTIES, INCLUDING ANY IMPLIED WARRANTIES OF MERCHANTABILITY, FITNESS FOR A PARTICULAR PURPOSE, TITLE OR NONINFRINGEMENT, OR ANY OTHER OBLIGATION ON MANUFACTURER'S PART. NO ORAL OR WRITTEN STATEMENTS MADE BY MANUFACTURER, EXCEPT THOSE MADE IN THIS WARRANTY SHALL BE CONSIDERED A WARRANTY OR CONSIDERED TO HAVE ANY LEGAL EFFECT. ADDITIONALLY, NO SAMPLES, MODELS, OR PROTOTYPES MANUFACTURER PROVIDES TO CUSTOMER SHALL BE CONSIDERED A WARRANTY OR CONSIDERED TO HAVE ANY LEGAL EFFECT.

CUSTOMER'S EXCLUSIVE REMEDIES FOR MANUFACTURER'S BREACH OF WARRANTY SHALL BE ONE OF THE FOLLOWING: (A) THE REPAIR OR REPLACEMENT OF THE DEFECTIVE PRODUCT; OR (B) THE REFUND OF THE PRICE CUSTOMER PAID FOR THE DEFECTIVE PRODUCT. THE REMEDIES SET FORTH ABOVE SHALL BE DETERMINED IN MANUFACTURER'S SOLE DISCRETION. ANY SHIPPING COSTS ASSOCIATED WITH VALID WARRANTY PRODUCTS THAT MANUFACTURER AND CUSTOMER HAVE MUTUALLY AGREED UPON SHALL BE PAID BY MANUFACTURER.

UNDER NO CIRCUMSTANCES WILL MANUFACTURER BE LIABLE FOR ANY INDIRECT, SPECIAL, PUNITIVE, INCIDENTAL, OR CONSEQUENTIAL DAMAGES RESULTING FROM THE SALE, MANUFACTURE, OR USE OF THE PRODUCT, WHETHER BASED UPON BREACH OF WARRANTY, BREACH OF CONTRACT, NEGLIGENCE, STRICT LIABILITY, OTHER TORT, OR ANY OTHER LEGAL THEORY. MANUFACTURER'S LIABILITY IN CONNECTION WITH THE SALE OR USE OF THE PRODUCT WILL NOT EXCEED THE PRICE OF THE PRODUCT UNDER ANY CIRCUMSTANCES. BY WAY OF EXAMPLE, IF A SINGLE PRODUCT CAUSES ANY DAMAGES, MANUFACTURER'S LIABILITY WILL NOT EXCEED THE PRICE OF THAT SINGLE PRODUCT. DAMAGES REFERRED TO IN THIS PROVISION INCLUDE, BUT ARE NOT LIMITED TO, LOSS OF PROFITS, REVENUE, OR USE OF THE PRODUCT; THE COST OF CAPITAL, SUBSTITUTE PRODUCTS, REPLACEMENT PRODUCTS, OR DOWN TIME; ANY CLAIMS OF THIRD PARTIES, INCLUDING, BUT NOT LIMITED TO, CUSTOMER'S CUSTOMERS OR OTHER USERS; DEATH; PERSONAL INJURY; AND INJURY TO PROPERTY.

## CE DECLARATION OF CONFORMITY

Manufacturer Declaration

According to EC Machinery Directive 2006/42/EC, Annex II A

We, MAGNA-MATIC W4599 County Road IW Waldo, WI 53093, herewith declare, that the following machine complies with the appropriate basic safety and health requirements of the EC Directive based on its design and type, as brought into circulation by us. In case of alteration of the machine, not agreed upon by us, this declaration will lose its validity.

Machine: MAG 12008, MAG 8000, MAG 9000, MAG-8100, MAG-8200

Applicable EC Directives: EC Machinery Directive 2006/42/EC  
EC Low - Voltage Directive 2006/95/EC

Applicable Harmonized Standards: BSENISO 12100:2010  
BSEN 61029-1:2009+A11:2010  
BSEN 61029-2-4:2011

Printed Name: Gerd F. Bauer II  
Title: Vice President  
Date: 1 January 2015

Authorized Signature:



Magna-Matic Corporation  
W4599 County Road IW  
Waldo WI 53093 USA

Phone: (920) 564-2366 - FAX: (920) 564-2368  
Toll Free USA & Canada **1-800-328-1110**  
<http://www.magna-matic.com>  
© Copyright 2023 All rights reserved