



DL-1300 Lift Table



OPERATING AND SAFETY INSTRUCTIONS

1. Consider the appropriate lifting range for the task you will be performing and adjust the "dual-lifting" mechanism if necessary before attempting to load equipment on the table surface.



2. If it is necessary to raise or lower equipment beyond the limits of any one lift range, transfer the load to a workbench temporarily in order to safely switch the "dual-lifting" mechanism to the other lift range. Then reload the table and continue operation.

3. Make sure the brake is securely engaged any time the table is stationary. Sudden shifts could occur during raising or lowering of the table without the brake secured, causing injury or damage to equipment.

4. Keep all bystanders clear of the lift whenever raising, lowering or transporting the lift under load.

5. Always lower the lift table to the bottom of its lift travel before transporting to any other area.

6. Do not attempt to operate this lift table on any ramp, incline or other uneven surface.

7. Make sure all loads are placed squarely on the table surface. Unbalanced loads could fall or cause the table to overturn.

8. Note the stated capacity of the DL300 Mobile Lift table you are operating as well as the weight of any components to be raised. Do not exceed the stated weight capacity limits.

9. Be observant whenever the DL300 is in operation. Keep hands and feet clear of any moving parts to avoid potential injury.

10. Be sure to clear any obstructions from the area under and around the lift before lowering the table to the floor.

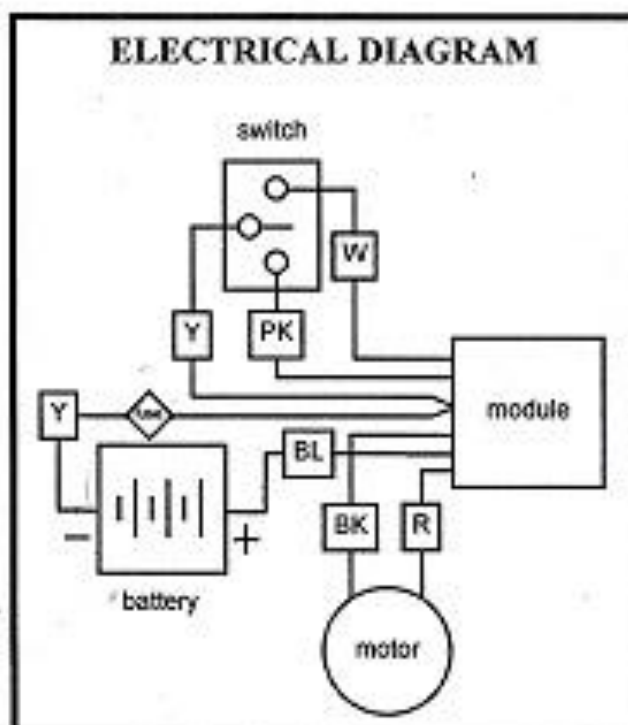

ASSEMBLY INSTRUCTIONS

Your DL300 has been delivered partially assembled. The final steps shown below are easily completed with the use of a 3/4" wrench.

Step 1: Bolt the base to the mast using the four 1/2-13 x 1" bolts that were used to package your lift table and the lock washers provided in the parts bag.

Step 2: Bolt the table assembly to the Mast using the two 1/2-13 x 2-1/4" bolts and lock washers provided in the parts bag.

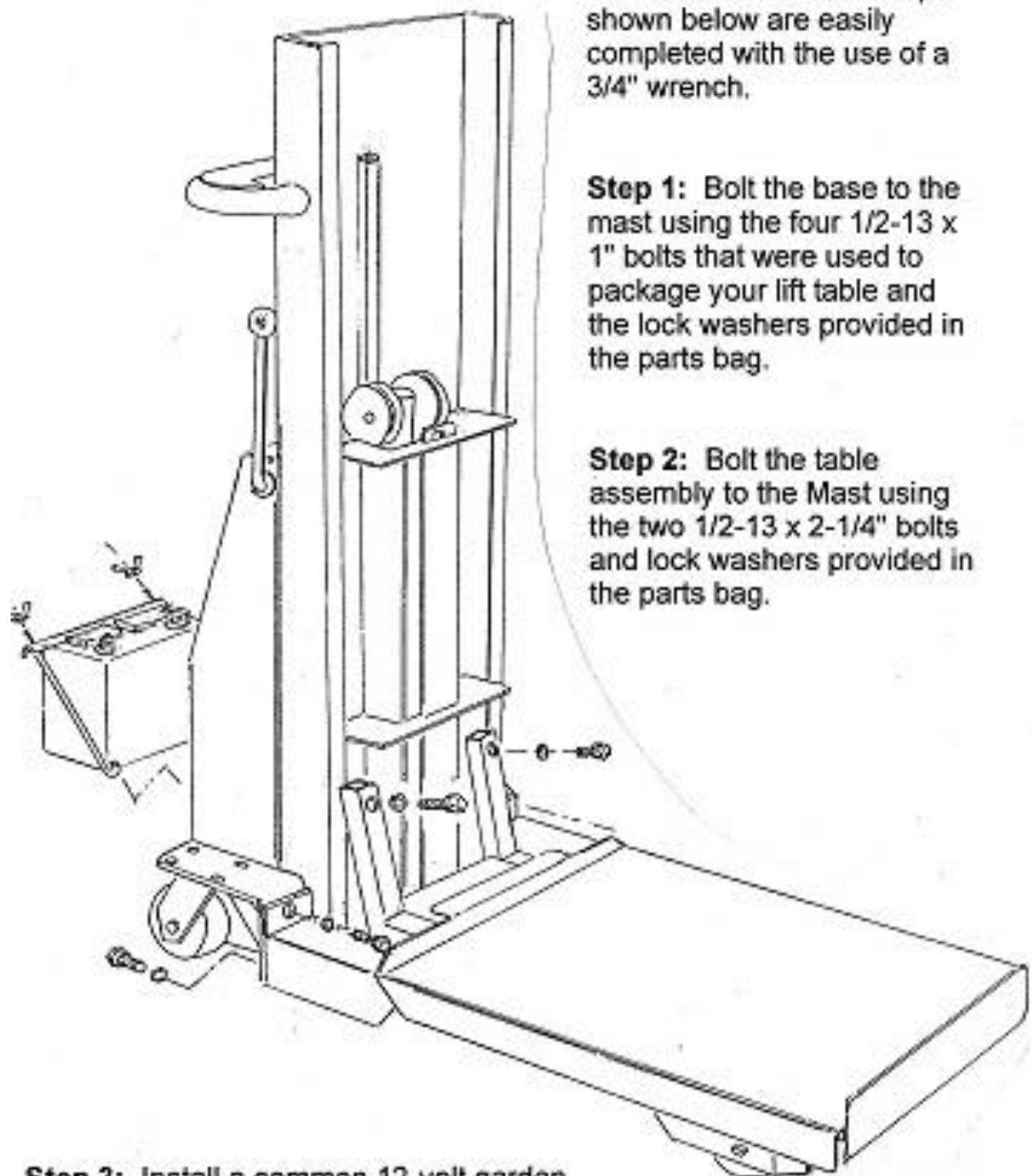

Step 3: Install a common 12-volt garden tractor battery (not included), using the J-Bolts and battery bracket provided. Connect the battery cables and replace the compartment cover.



Tray in lowest position.



Tray relocated to upper lift range.



Tray in highest position.



◆ ◆ ◆ ◆ ◆ **FIVE-YEAR LIMITED WARRANTY** ◆ ◆ ◆ ◆ ◆

All Trion products are engineered, manufactured and tested to provide many years of satisfactory performance under normal use. Trion Lifts, Inc. pledges to the original owner that, should there be any defect in material or workmanship during the first FIVE years after purchase, we will repair or replace the defective part or component promptly, at our option, and with no cost to the purchaser.

Our technicians are qualified to assist you in determining the repairs or replacement parts needed. To obtain service under the warranty, please contact the factory service department at 1-800-426-3634 during normal business hours and describe the defect BEFORE attempting any repair work. Failure to follow these instructions may void this warranty.

The warranty applies only to parts or components which are defective and does not cover repairs and adjustments necessary due to normal wear, misuse or accidents. Neither the sale personnel nor the seller nor any other person is authorized to make any warranty other than those described above, or to extend the duration of any warranty beyond the time period described above.

There is no other express warranty. All implied warranties or merchantability and fitness of use are limited to the duration of the express warranty.

Trion Lifts, Inc is not liable for indirect, incidental or consequential damages in connection with the use of the product, including any cost or expenses of providing substitute equipment or service during periods of malfunction or non-use.

This warranty gives specific legal rights and you may also have other rights which vary from state to state.

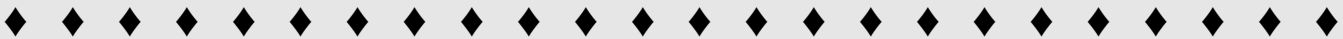

Trion have pledged to be “Your Partner in Productivity,” not only by providing you with the most efficient turf equipment lift available anywhere, but by making ourselves available to you to answer any questions or needs you may have with regard to our products.

Do you have questions about any of the installation steps outlined in this manual?

Do you need assistance in planning a new facility layout that will include your new workstation?

Do you want more information about enhancing your preventative maintenance program using your new Trion?

Do you have suggestions for various turf maintenance applications?

Our goal is your safety and satisfaction. We welcome any questions or comments you may have. Please call Par West at 1-714-893-1555 or you may email us at sales@parwest.com.



PAR WEST

1-714-893-1555
Huntington Beach, CA 92647



Visit our Website for all Products:
www.parwest.com

